

TOP VIEW

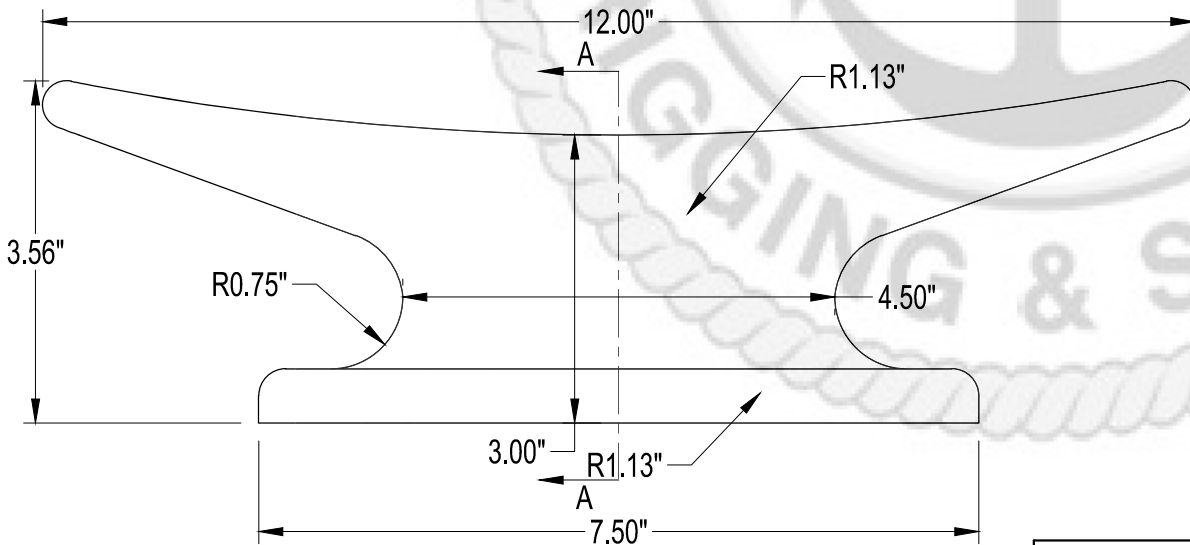

SIDE VIEW

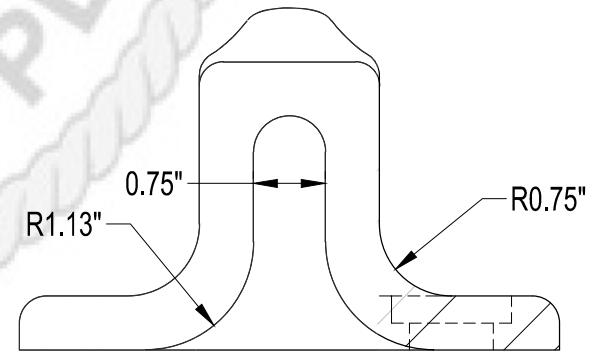

SECTION A-A

<b>PROPRIETARY AND CONFIDENTIAL</b> THE INFORMATION CONTAINED IN THIS DRAWING IS THE SOLE PROPERTY OF ACE MARINE, ANY REPRODUCTION IN PART OR AS A WHOLE WITHOUT THE WRITTEN PERMISSION OF ACE MARINE IS PROHIBITED. SCALE: 1:2 DATE: 10-10-11 DRAWN BY: DWG	<b>ACE MARINE RIGGING &amp; SUPPLY, INC</b> 600 ARENDELL STREET MOREHEAD CITY, NC 28557 PHONE (252)726-6620 FAX (252)726-7499	<b>DESCRIPTION</b> 12" CLEAT	
		<b>PART NO.</b> AMC-12-3	
		<b>MATERIAL</b> CAST STEEL	<b>SHEET SIZE</b> A